

GAZ Rear Telescopic Damper Conversion Kit Fitting Instructions

Part Number: TMG30715G
Description: GAZ Rear Telescopic Damper Conversion Kit
Applications: MGB, BGT & V8, MGC Models
Kit Contents:

BH607241	BOLT, 7/16 UNF X 3"	4	Upper bracket to chassis
BH608181	BOLT, 1/2 UNF X 2.25"	2	Damper to upper bracket
BH608201	BOLT, 1/2 UNF X 2.5"	2	Damper to lower bracket
GHF203	NUT, plain, 7/16"	4	Upper bracket to chassis
GHF223	NUT, Nyloc 3/8" UNF	8	
GHF275	NUT, Nyloc, 1/2 UNF	2	Lower damper mounting
GHF303	WASHER, plain, 7/16" X 7/8"	8	Upper bracket to chassis
PWZ308	WASHER, plain, 1/2" X 1.25"	4	Damper mounting
GHF334	WASHER, spring, 7/16"	4	Upper bracket to chassis
GHF335	WASHER, spring, 1/2"	2	Damper mounting, upper
TMG3720L	BRACKET, LH	1	Damper to chassis
TMG3720R	BRACKET, RH	1	Damper to chassis
TT30902	SPACER, 10mm	2	Lower damper mounting
TMG30713	DAMPER, telescopic, GAZ	2	

Check the contents of the kit and read through these instructions to familiarize yourself with the procedure before commencing work.

Safety Precaution

1. Chock the front wheels to stop movement. (Wheel chocks Part No: DMR54500).
2. Jack up the car and support the bodyshell on the chassis rail in front of the rear spring hangers. Use suitable axle stands and ensure the car is safe before working underneath. The leaf spring must be free and not used as a support for the car. (Original type side jack Part No: BHA5329. Trolley Jack Part No: CTR081. Axle stands Part No: CTR078).

Installation Instructions

1. Remove the wheels.
2. Remove lever arm dampers and links.
3. Using a jack, support the leaf spring in front of the axle. Remove the lower spring plates by releasing the U bolt nuts.
4. Before refitting please check, and replace as necessary, spring locator rubber pads and bump stop pedestals on top of the axle. We recommend Polyurethane components where available.

Please Note: It is imperative that when fitting a telescopic damper conversion the bump stops must be used.

5. Refit the damper locating plates. Use the plate taken from the RH side on the LH side, and vice-versa. This allows the damper mounting hole to be re-located forward of the axle as per **image 1**. Replace the U bolt nuts and washers with those supplied in the kit and tighten to a torque of 26lb.ft (3.72kg/m).
6. Fit the upper brackets. These fit in place of the lever arm dampers. These must be installed as per **image 2** with the damper holes above the mounting holes and with the chamfer forward.
7. Fit the damper unit. Ensure the damper is the correct way up. If fitting Gaz dampers ensure the adjuster is to the lower mounting. Using the 1/2" UNF X 2.25" long bolt, spring washer and plain washer loosely fit to the top mounting bracket. Using the 1/2" UNF X 2.5" long bolt fit through the spring plate, spacer, damper, washer and nyloc nut and tighten the damper mounting bolts to 50lb.ft (6.9kg/m).
8. Recheck all nuts and bolts are tight and complete the installation.
9. Refit wheels and test drive. After test drive re-check the installation to ensure all fixings are tight and the installation is safe.

Image 1

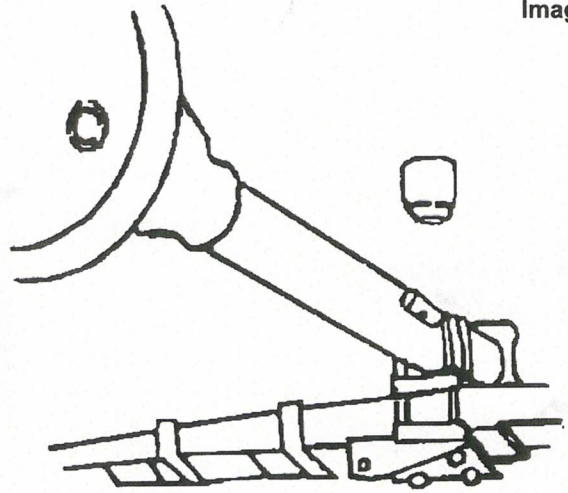

Damper Mounting New Position

Image 2

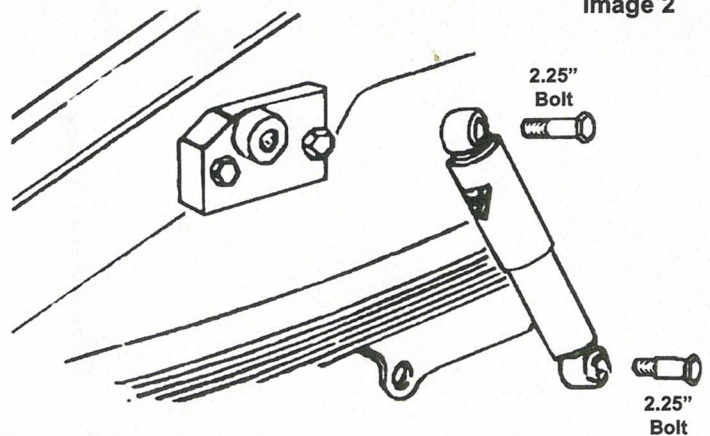
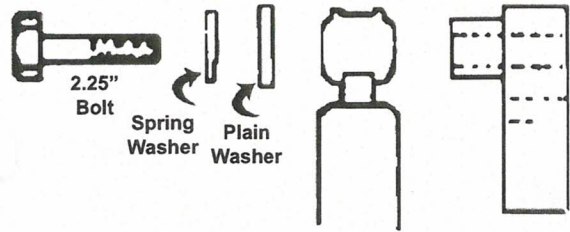

Image 3

Setting The Dampers

The dampers are supplied set for road use. We recommend that you check that both dampers are set to the same point before use. We also recommend that you try running with this setting for a while to determine if it suits your needs. Dampers can then be adjusted to suit your needs in accordance with the manufacturer's information supplied.



Anti-Tramp Bars

If fitting a telescopic conversion kit with our anti-tramp bars please note that adaptor kits may be required. Please refer to the catalogue for more information.

Exhaust Clearance

We have found on some cars that exhaust clearance is reduced between the LH lower damper mounting and the exhaust pipe. If clearance is a problem, the bolt can be inserted the other way round, through the damper first.

Image 4

